



ELSEVIER

Contents lists available at ScienceDirect

HardwareX

journal homepage: [www.elsevier.com/locate/ohx](http://www.elsevier.com/locate/ohx)

## Low-cost and open-source neonatal incubator operated by an Arduino microcontroller

Rubén Cuervo<sup>a,\*</sup>, Miguel A. Rodríguez-Lázaro<sup>a</sup>, Ramon Farré<sup>a,b,c</sup>, David Gozal<sup>d</sup>, Gorka Solana<sup>e,\*</sup>, Jorge Otero<sup>a,b,f,\*</sup>

<sup>a</sup> Unitat de Biofísica i Bioenginyeria, Facultat de Medicina, Universitat de Barcelona, Barcelona, Spain

<sup>b</sup> CIBER de Enfermedades Respiratorias, Madrid, Spain

<sup>c</sup> Institut Investigacions Biomèdiques August Pi Sunyer, Barcelona, Spain

<sup>d</sup> Departments of Child Health and Medical Pharmacology and Physiology, and The Child Health Research Institute, University of Missouri School of Medicine, Columbia, MO, USA

<sup>e</sup> Faculdade de Engenharias e Tecnologias, Universidade Save, Maxixe, Mozambique

<sup>f</sup> Institut de Bioenginyeria de Catalunya, Barcelona, Spain

### ARTICLE INFO

#### Keywords:

Neonatal incubator  
Arduino  
Control systems  
Low-cost  
Preterm infant  
Developing countries  
Low-resource regions

### ABSTRACT

An unacceptably large number of newborn infants die in developing countries. For a considerable number of cases (particularly in preterm infants), morbidity and mortality can be reduced by simply maintaining newborn thermal homeostasis during the first weeks of life. Unfortunately, deaths caused by prematurity remain inordinately common in low- and middle-income countries (LMICs) due to reduced access to incubators in light of the high cost of commercially available devices. We herein describe and test a low-cost and easy-to-assemble neonatal incubator created with inexpensive materials readily available in LMICs. The incubator is based on an Arduino microcontroller. It maintains controlled temperature and relative humidity inside the main chamber while continuously measuring newborn weight progress. Moreover, the incubator has a tilting bed system and an additional independent safety temperature alarm. The performance of the novel low-cost neonatal incubator was evaluated and successfully passed the IEC 60601-2-19 standards. In the present work, we provide all the necessary technical information, which is distributed as open source. This will enable assembly of very low-cost (<250 €) and fully functional incubators in LMICs that should help reduce neonatal mortality.

Specifications table  
Hardware name  
Subject areaHardware type

Open-Source License  
Closest commercial analog

Low-cost neonatal incubator

- Biomedical Engineering
- Electronics Engineering
- Neonatology
- Maintenance of thermal conditions
- Open-source alternative to existing device

GPL v3  
Neonatal Incubator

(continued on next page)

\* Corresponding authors at: Unitat de Biofísica i Bioenginyeria, Facultat de Medicina, Universitat de Barcelona, Barcelona, Spain (J. Otero).  
E-mail addresses: [ruben1712@gmail.com](mailto:ruben1712@gmail.com) (R. Cuervo), [gorsol@gmail.com](mailto:gorsol@gmail.com) (G. Solana), [jorge.otero@ub.edu](mailto:jorge.otero@ub.edu) (J. Otero).

<https://doi.org/10.1016/j.ohx.2023.e00457>

Received 19 July 2022; Received in revised form 4 July 2023; Accepted 16 July 2023

Available online 17 July 2023

2468-0672/© 2023 Published by Elsevier Ltd.

This is an open access article under the CC BY-NC-ND license

(<http://creativecommons.org/licenses/by-nc-nd/4.0/>).

(continued)

Cost of hardware  
Source File Repository

236.7 €  
<https://doi.org/10.17632/k59v85zjr5.1>

## 1. Hardware in context

A baby born alive before the 37th week of pregnancy is defined as a premature (or preterm) infant. Prematurity is the main cause of death among children under five years of age [1], and it is estimated that more than 10 % of the newborns worldwide, are born prematurely every year [2].

Preterm infants present complications derived from insufficient homeothermic temperature regulation and the underdevelopment of several tissues, such as fat and skin layers. Most of these problems can be avoided by simply maintaining the homeostatic thermal conditions of the newborn (normothermia) during the first weeks of life [3,4]. The use of neonatal incubators and radiant warmers is the common solution used in maternity hospitals around the world for taking care of these preterm infants.

Neonatal incubators were invented in 1880 [5] and, since then, have evolved by incorporating new technologies. Modern incubators as used nowadays are highly precise, exhibit fast adaptive responses, are easy to use, and are visually appealing systems. However, as a consequence of such technical improvements, there has been a steady increase in their cost, with some incubators costing up to 30 k€ [6]. For this reason, many hospitals in low- and middle-income countries (LMICs) cannot afford to buy these costly neonatal incubators. This is one of the main reasons accounting for the observation that more than 80% of preterm deaths worldwide take place in LMICs [1].

Accordingly, there is an urgent need to resolve the problem of insufficient infant incubators in under-resourced regions. Some solutions have been proposed in the last decades with the most common consisting of donations by developed countries of new, used, or outdated radiant warmers and neonatal incubators. However, charitable gifts are only a partial solution, as the high complexity of the donated equipment requires trained personnel to use them correctly and also to perform routine maintenance of the devices. Other approaches, such as Kangaroo Mother Care (KMC) [7] where the infants are carried (usually by their mother) with skin-to-skin contact can provide improved care, and have been adopted in many of these regions, but certain barriers such as parental working conditions, cultural norms, among others, have slowed widespread uptake of this solution [7,8].

In this work, we present the design of a low-cost (less than 250 €) neonatal incubator created with materials readily available in under-resourced regions (or by e-commerce). The device is easy to build and handle and was designed with the objective of being produced locally as needed to effectively contribute and reduce the high mortality of preterm infants associated with the lack of neonatal incubators in LMICs.

## 2. Hardware description

The scaffold of the neonatal incubator is fully constructed by using phenolic plywood, a humidity resistant long-lasting thermal-insulating material. The hood (newborn space) has a size of  $80 \times 50 \times 50 \text{ cm}^3$  and it contains three lateral and a big frontal transparent regions made of polyethylene (Fig. 1). The frontal part can be opened using a handle and it presents two holes covered by movable lids to insert personnel arms to interact with the newborn while maintaining this frontal door closed. Moreover, a wooden bed fabricated with plywood and coupled to a weight sensor to measure the weight evolution of the newborn is placed inside the hood. A horizontal

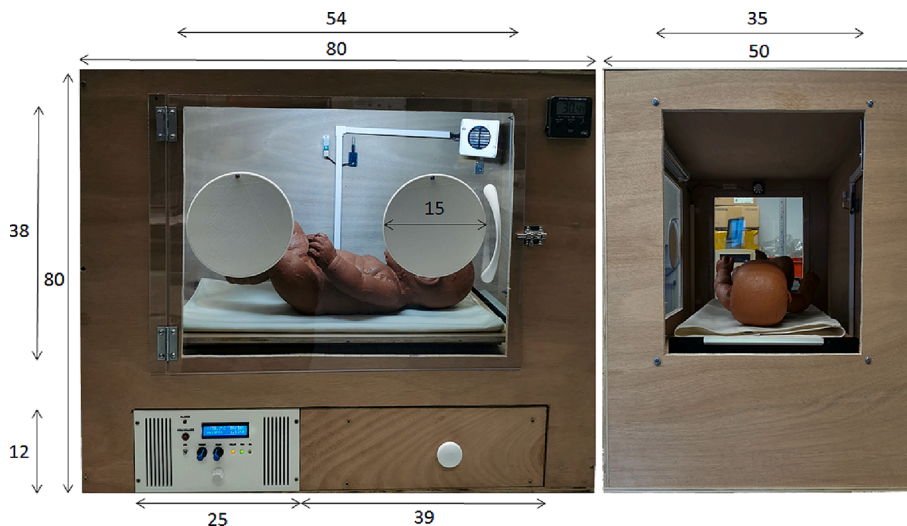

Fig. 1. Frontal (left) and lateral (right) view of the low-cost neonatal incubator (dimensions in cm).

hinge system with custom wooden wedges is placed to tilt this bed from 0° to 12°. Tilting is of vital importance to significantly reduce gastroesophageal reflux and facilitate several respiratory processes of the newborn [9].

A second cabin of 80 × 15 × 50 cm<sup>3</sup> is located beneath the hood and is meant to accommodate all of the electronic components required to make the device functional, as well as the humidification system. These two sections are separated into two asunder drawers (Fig. 1).

The equipment incorporates an easy-to-tune control of relative humidity (RH) and temperature. Temperature maintenance is achieved by implementing a PI control on a heater and fan system located inside the incubator's hood. Concerning the RH regulation, it is achieved by means of a bang-bang control with hysteresis using an ultrasonic nebulizer coupled to a fan located in an inferior drawer of 30 × 12 × 25 cm<sup>3</sup> as well as a dehumidifying fan, located in the incubator's hood, which introduces external air when RH needs to be markedly reduced.

Finally, the neonatal incubator presents interior fans for temperature and RH homogenization and for air regeneration as well as an internal and an external alarm system decoupled from the main control system, to warn when life-threatening levels occur inside the device.

### 3. Design files

Design and software files necessary to build the low-cost neonatal incubator presented in this work are distributed under the GPL license and they can be found in the [supplementary materials](#) of this manuscript and at the following public repositories: GitHub: <https://github.com/rubencn4/low-cost-neonatal-incubator-UB>; Mendeley Data: <https://doi.org/10.17632/k59v85zjr5.1>.

Design filename	File type	Open-source license	Location of the file inside the repository
<i>SHTC3 support</i>	<i>STL file</i>	<i>GPL v3</i>	<i>STL files folder</i>
<i>Electronics_drawer_frontal_part</i>	<i>STL file</i>	<i>GPL v3</i>	<i>STL files folder</i>
<i>Lids</i>	<i>STL file</i>	<i>GPL v3</i>	<i>STL files folder</i>
<i>Bed_handle</i>	<i>STL file</i>	<i>GPL v3</i>	<i>STL files folder</i>
<i>Structure blueprints</i>	<i>PDF file</i>	<i>GPL v3</i>	<i>Structure blueprints folder</i>
<i>Build Instructions</i>	<i>PDF file</i>	<i>GPL v3</i>	<i>Build instructions folder</i>
<i>Code</i>	<i>INO file</i>	<i>GPL v3</i>	<i>Arduino Code folder</i>
<i>PCB layout</i>	<i>JPG file</i>	<i>GPL v3</i>	<i>Electronics folder</i>

### 4. Bill of materials

All the materials used as well as their prices in euros for common e-commerce platforms are the following (as for June 2023):

Component	Number	Cost per unit (€)	Total cost (€)	Source of materials
Arduino Nano ES-EL-CB-005	1	4,7	4,7	<a href="https://www.amazon.es/ELEGOO-ATmega328P-Compatible-Arduino-Proyecto/dp/B0716T2L77">https://www.amazon.es/ELEGOO-ATmega328P-Compatible-Arduino-Proyecto/dp/B0716T2L77</a>
12 V Power source Orno OR-ZL	1	19,2	19,2	<a href="https://www.amazon.es/Orno-Alimentación-Protección-Sobrecargas-Cortocircuitos/dp/B09BVXY4LV/">https://www.amazon.es/Orno-Alimentación-Protección-Sobrecargas-Cortocircuitos/dp/B09BVXY4LV/</a>
IRFP260NPBF transistor (MOSFET)	1	2,6	2,6	<a href="https://www.amazon.es/BOJACK-Transistores-IRFP260N-N-Channel-IRFP260NPBF/dp/B086C1JZPJ/">https://www.amazon.es/BOJACK-Transistores-IRFP260N-N-Channel-IRFP260NPBF/dp/B086C1JZPJ/</a>
TIP122 transistor	1	0,5	0,5	<a href="https://www.amazon.es/s?k=tip122&amp;ref=nb_sb_noss_1">https://www.amazon.es/s?k=tip122&amp;ref=nb_sb_noss_1</a>
BC549 transistor	1	0,07	0,07	<a href="https://www.amazon.es/s?k=BC549&amp;_mk_es_ES=%C3%85M%C3%85%C5%BD%C3%95%C3%91&amp;crid=3EYBCKTMB8F1T&amp;sprefix=bc549+%2Caps%2C171&amp;ref=nb_sb_noss">https://www.amazon.es/s?k=BC549&amp;_mk_es_ES=%C3%85M%C3%85%C5%BD%C3%95%C3%91&amp;crid=3EYBCKTMB8F1T&amp;sprefix=bc549+%2Caps%2C171&amp;ref=nb_sb_noss</a>
SHTC3 sensor	1	3,2	3,2	<a href="https://www.amazon.com/DollaTek-precisión-temperatura-medición-comunicación/dp/B081JMRLD8">https://www.amazon.com/DollaTek-precisión-temperatura-medición-comunicación/dp/B081JMRLD8</a>
Heater Fdit PTC 100 W 12 V	1	7,5	7,5	<a href="https://www.amazon.es/Fdit-Desodorante-Calefacción-Calentamiento-Temperatura/dp/B07JP7CXDQ/">https://www.amazon.es/Fdit-Desodorante-Calefacción-Calentamiento-Temperatura/dp/B07JP7CXDQ/</a>
HX711 sensor	1	8	8	<a href="https://www.amazon.es/Sensor-módulo-Escala-Arduino-Raspberry/dp/B07G25Y95L">https://www.amazon.es/Sensor-módulo-Escala-Arduino-Raspberry/dp/B07G25Y95L</a>
LCD I2C AZDelivery HD44780	1	3,6	3,6	<a href="https://www.amazon.es/AZDelivery-Serielle-Schnittstelle-Bundle-Parent/dp/B0821N9LCV">https://www.amazon.es/AZDelivery-Serielle-Schnittstelle-Bundle-Parent/dp/B0821N9LCV</a>
2 pins connector	8	0,024	0,2	<a href="https://www.amazon.es/XTVTX-conector-enchufe-vivienda-engarzado/dp/B0928ND9FJ/">https://www.amazon.es/XTVTX-conector-enchufe-vivienda-engarzado/dp/B0928ND9FJ/</a>
3 pins connector	4	0,024	0,1	<a href="https://www.amazon.es/XTVTX-conector-enchufe-vivienda-engarzado/dp/B0928ND9FJ/">https://www.amazon.es/XTVTX-conector-enchufe-vivienda-engarzado/dp/B0928ND9FJ/</a>
4 pins connector	4	0,024	0,1	<a href="https://www.amazon.es/XTVTX-conector-enchufe-vivienda-engarzado/dp/B0928ND9FJ/">https://www.amazon.es/XTVTX-conector-enchufe-vivienda-engarzado/dp/B0928ND9FJ/</a>
Strip	2	0,63	1,26	<a href="https://es.rs-online.com/web/p/bloques-terminales-estandar/7822841">https://es.rs-online.com/web/p/bloques-terminales-estandar/7822841</a>
470 Ω resistance	4	0,03	0,12	<a href="https://es.rs-online.com/web/p/resistencias-de-montaje-en-orificio-pasante/1251133">https://es.rs-online.com/web/p/resistencias-de-montaje-en-orificio-pasante/1251133</a>

(continued on next page)

(continued)

Component	Number	Cost per unit (€)	Total cost (€)	Source of materials
220 Ω resistance	3	0,09	0,27	<a href="https://es.rs-online.com/web/p/resistencias-de-montaje-en-orificio-pasante/1616163">https://es.rs-online.com/web/p/resistencias-de-montaje-en-orificio-pasante/1616163</a>
220 μF capacitor	1	0,22	0,22	<a href="https://es.rs-online.com/web/p/condensadores-de-aluminio/7395282">https://es.rs-online.com/web/p/condensadores-de-aluminio/7395282</a>
LEDs	4	0,024	0,096	<a href="https://www.amazon.es/KINYOOO-500pcs-redondo-amarillo-colores/dp/B07DPJ23YT/">https://www.amazon.es/KINYOOO-500pcs-redondo-amarillo-colores/dp/B07DPJ23YT/</a>
Bakelite board	1	1,68	1,68	<a href="https://diotronic.com/placa-de-fv-y-baq-virgen-fotosensible/6013-placa-posit-baq-60x80">https://diotronic.com/placa-de-fv-y-baq-virgen-fotosensible/6013-placa-posit-baq-60x80</a>
Cables	1	2,26	2,26	<a href="https://es.farnell.com/velleman-sa/k-mowm/wire-kit-8x5m-2x10m-24awg-singlecore/dp/3498572">https://es.farnell.com/velleman-sa/k-mowm/wire-kit-8x5m-2x10m-24awg-singlecore/dp/3498572</a>
Pushbutton	1	0,08	0,08	<a href="https://www.amazon.es/Gebildet-6x6x8mm-MomentáneoTáctil-Interruptor-Arduino/dp/B082DBBPGC/">https://www.amazon.es/Gebildet-6x6x8mm-MomentáneoTáctil-Interruptor-Arduino/dp/B082DBBPGC/</a>
Potentiometer	2	0,44	0,88	<a href="https://www.amazon.es/RUNCCI-YUN-Potenciómetro-Resistencia-variables-Raspberry/dp/B09LM5BVWP/">https://www.amazon.es/RUNCCI-YUN-Potenciómetro-Resistencia-variables-Raspberry/dp/B09LM5BVWP/</a>
Dissipator for the MOSFET B081GS15N6	1	0,9	0,9	<a href="https://www.amazon.es/s?k=B081GS15N6&amp;i=industrial&amp;_mk_es=%C3%85M%C3%85%C5%BD%C3%95%C3%91&amp;crd=X347CXX81X25&amp;sprefix=b081gs15n6%2Cindustrial%2C201&amp;ref=nb_sb_noss">https://www.amazon.es/s?k=B081GS15N6&amp;i=industrial&amp;_mk_es=%C3%85M%C3%85%C5%BD%C3%95%C3%91&amp;crd=X347CXX81X25&amp;sprefix=b081gs15n6%2Cindustrial%2C201&amp;ref=nb_sb_noss</a>
PLA	0,25	43,77	10,94	<a href="https://es.rs-online.com/web/p/materiales-para-impresion-3d/1830259">https://es.rs-online.com/web/p/materiales-para-impresion-3d/1830259</a>
Gutter	1	3,1	3,1	Local store
Handle	1	1,9	1,9	Local store
Knob	1	0,2	0,2	Local store
Latch	1	1,6	1,6	Local store
Phenolic plywood	4	21,31	85,24	Local store
Polyethylene crystal	0,5	49,62	24,81	Local store
PVC tube	0,25	1,29	0,3225	Local store
PVC elbow	1	0,21	0,21	Local store
Hinge	0,5	4,85	2,43	Local store
Wood screws	70	0,037	2,59	Local store
Screws	20	0,02	0,4	Local store
Washers	20	0,029	0,58	Local store
Self-locking washers	2	0,021	0,042	Local store
LED strip	1	8	8	<a href="https://www.amazon.es/gp/product/B08RHXDNB6/">https://www.amazon.es/gp/product/B08RHXDNB6/</a>
Metal plates	1	3,07	3,07	Local store
Tupperware	1	1,35	1,35	Local store
Homogenization fan Amina AF8	1	2,89	2,89	<a href="https://www.tacens-anima.com/cooling/af8/">https://www.tacens-anima.com/cooling/af8/</a>
Humidification anddehumidification fans RepRap 3010	2	0,97	1,94	<a href="https://es.aliexpress.com/item/32847782448.html">https://es.aliexpress.com/item/32847782448.html</a>
External thermometer	1	12,95	12,95	Local store
Ultrasonic nebulizer Fayme 283703A1	1	14,6	14,6	<a href="https://www.amazon.es/Fayme-Humidificador-ultrasonico-Nebulizador-Fabricante/dp/B098F748W8/">https://www.amazon.es/Fayme-Humidificador-ultrasonico-Nebulizador-Fabricante/dp/B098F748W8/</a>

Total cost of materials for the construction of one incubator is 236.7 €. However, it is important to highlight that the listed components (which are the ones used for the creation of the first prototype presented herein) can be replaced by similar ones according to their availability and suitability. For example, if there is no availability of 3D printers, PLA structures can be replicated by wooden structures while preserving the same functionality.

As additional cost reduction, the phenolic plywood used for the structure of the device could be changed by a thick layer of corrugated cardboard, which stacked presents similar thermal properties with a much-reduced cost. Also, additional aesthetical components such as the LED strip, the lateral windows, the hinge, the handle, the latch and the gutter could also be removed. In case the aforementioned changes are implemented, the equipment cost would be reduced to 162.5 €.

## 5. Build instructions

### 5.1. Structure fabrication

The structure of the neonatal incubator can be replicated with exactitude by using the complete drafts for the wooden parts in the blueprints file. Phenolic plywood (4 m<sup>2</sup>) should be cut with a jigsaw in:

- Two 80 × 65 cm<sup>2</sup> panels for the front and back walls of the incubator.
- Two 80 × 50 cm<sup>2</sup> panels for the top and bottom walls of the incubator.
- Two 65 × 48 cm<sup>2</sup> panels for the lateral walls of the incubator.
- One 78 × 48 cm<sup>2</sup> panel for the second floor which will make the separation between the two compartments (hood and bottom cabin).
- Two 30 × 12 cm<sup>2</sup>, two 23 × 12 cm<sup>2</sup> and two 28 × 23 cm<sup>2</sup> panels for the humidifying system drawer.
- One 25 × 12 cm<sup>2</sup>, two 23 × 12 cm<sup>2</sup> and two 23 × 23 cm<sup>2</sup> panels for the electronics drawer.



- One  $60 \times 34 \text{ cm}^2$  and one  $50 \times 20 \text{ cm}^2$  panel for the bed.
- One  $48 \times 15 \text{ cm}^2$  panel for the barrier to place the humidifier tube and to sustain the second floor and an additional  $20 \times 15 \text{ cm}^2$  panel to further sustain it.

Once all the panels are obtained, create the  $31 \times 38 \text{ cm}^2$  openings for the lateral windows, the  $50 \times 38 \text{ cm}^2$  aperture for the frontal window and the  $64 \times 12 \text{ cm}^2$  bottom incision in the frontal panel for the anterior part of the drawers. Note that the openings for the windows are 2 cm smaller than the polyethylene crystal for each side so as to obtain a better sealing.

Subsequently, fix the lateral windows to their respective walls by using self-threading screws. For the frontal window, as it needs to be fixed by a hinge and, additionally, the door had to close completely without letting any notable leakages, a 4 mm thick PMMA rectangle must be introduced to the left of the window to screw the hinge to it and obtain a mobile door (Fig. 2). To keep it closed, a latch must be placed on the opposite side. To conclude this window, perform two 6 cm radius holes equidistantly covering them with two 7.5 cm radius 3D printed structures (which can be found in *Lids.stl* file) that are fixed with self-threading screws complemented by a spring nut to achieve that the circular lids stay on top (Fig. 2) without disturbing the work of the physician. These lids can be also fabricated in transparent material to allow full visibility of the newborn without the need of moving their position.

Then, place the  $48 \times 15 \text{ cm}^2$  panel and the  $20 \times 15 \text{ cm}^2$  panel at the beneath compartment in the positions indicated in the blueprints file, to correctly sustain the second floor (where the newborn will be located) and introduce the  $78 \times 48 \text{ cm}^2$  panel at the top of it.

Finally, join all the panels forming the neonatal incubator structure (two  $80 \times 65 \text{ cm}^2$ , two  $80 \times 50 \text{ cm}^2$  and two  $65 \times 48 \text{ cm}^2$ ) by using wood screws. Note that the ceiling and one of the lateral sides should be left unscrewed to further manipulate the inside parts.

### 5.2. Bed construction

The bed inclination can be adjusted  $0^\circ$  to  $12^\circ$  and the weight of the infant when flat-positioned should be measured accurately. For weight measurement, a second structure of  $50 \times 20 \text{ cm}^2$  needs to be constructed and fixed to the sensor by using two metal plates. Place the module between the metal plates with screws and self-locking washers as shown in Fig. 3A, allowing the metal beam of the sensor to sustain the entire load placed in the bed without any compensation.

To allow bed inclination, fix the panel by using a hinge to the left side of the incubator hood. Then, create custom wooden wedges with the desired inclination by using a jigsaw to place them below the border opposite to the hinge, located at the baby head, elevating the bed just by the desired angle. To accompany this movement and force the bed not to be seized instead of the support, introduce and fix with screws the PLA structure with a handle (Fig. 3B) found at *Bed.handle.stl* in the right part of the structure. In Fig. 3C,D can be observed how the bed is inclined  $6^\circ$  and  $12^\circ$  by using the wedges.

### 5.3. Ventilation

To properly ventilate the hood, two 12 V DC fans are used. Fans should produce an air speed below 0.35 m/s over the newborn body [10] while being ultra-silent to harm the baby by causing a noticeable increase in the intracranial pressure [11] with consequences for the health and cochlear function of preterm newborn [12]. Air speed was measured by using a hot wire anemometer (405i, Testo, Germany) in the 5 different locations inside the incubator, as indicated by the ICE standard [10] with all the fans at maximum speed, being the air speed was below 0.3.5 m/s in all locations.

The first fan must be incorporated to the lateral window located at the newborn's feet to reduce humidity and, when turned off, to



Fig. 2. Movable lids of the front window and the hinge-latch mechanism for its opening.

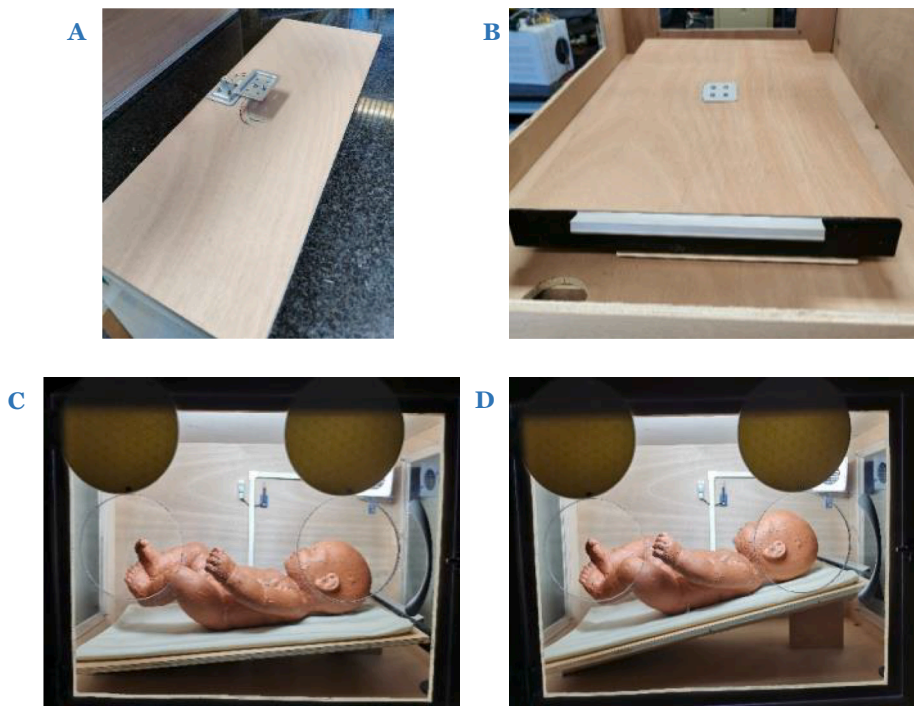

Fig. 3. (A) Weight sensor placement. (B) PLA structure with the handle. Inclination of the bed 6° (C) and 12° (D) by using the wooden wedges.

let the air regenerate. As this fan will introduce air from outside of the device, create a custom hole and fix the fan to this hole through screws. The second fan is utilized to homogenize the temperature and RH inside. Fix this one by placing it at the top of a mobile metal platform, attached to the corner between the frontal and the right lateral wall, allowing turning it 90° to select its idoneous orientation.

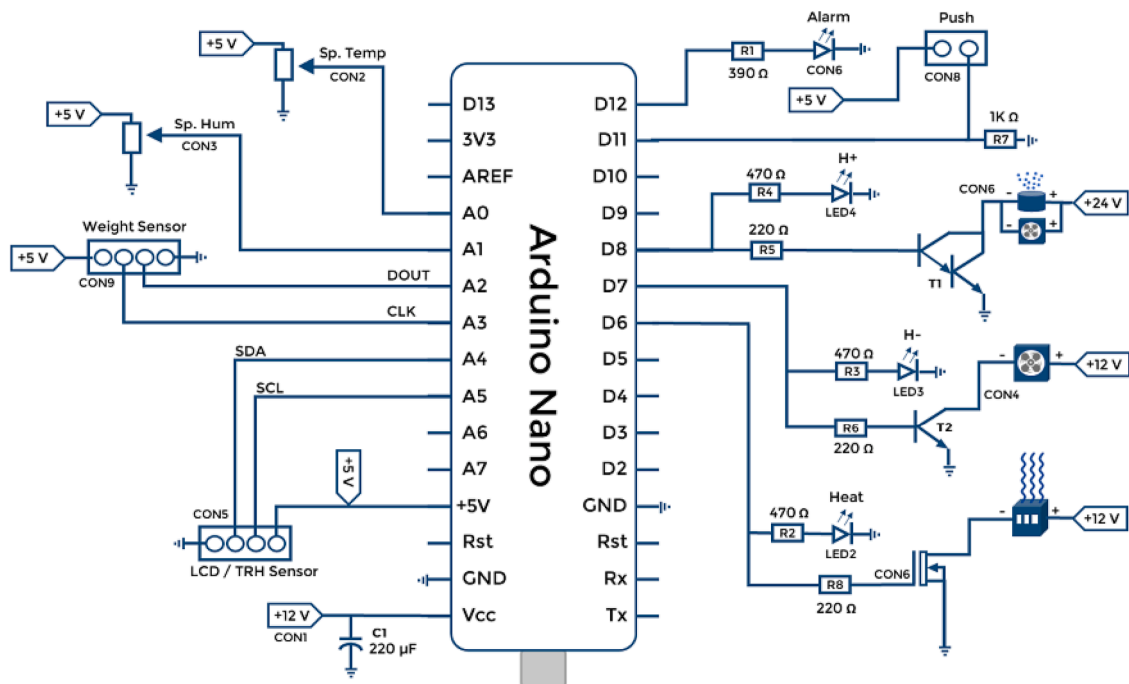

Fig. 4. Schematic of the electronic circuit.

#### 5.4. Temperature and humidity control

For temperature control, the incubator incorporates a 100 W ceramic heater with fan in front of the homogenization fan. It is mounted by utilizing a metal plate fixed to the wall which allows a 90° rotation for its correct placement.

A humidity generator system cannot be placed inside of the incubator door because it could be a font of microorganisms, it could have leakage risk due to manipulations of the infant and the humidifier could not be filled with water without completely opening the child's dome, thus losing the accumulated temperature and humidity. To solve this, create a 30 × 12 × 25 cm<sup>3</sup> drawer and to locate it in the second compartment (beneath the hood) while placing a 1.2 L plastic container glued to the base of the drawer. Subsequently, place the Fayme ultrasonic humidifier inside the Tupperware by creating two holes at each side of it. In the left hole place a 12 V fan that will propel the humidified air forward, and at the second one, fix a PVC tube which fits into an adaptor located in the barrier, and that directly connects to the incubator hood by means of a PVC elbow. This new system allows for refills of water to be performed completely independent from the infant hood, and just by extracting the drawer from the bottom part of the incubator, refilling it and later placing it again to its side by fitting the PVC tube to its adaptor, the humidification system could keep working correctly.

Regarding the humidity sensor, it needs to be fixed inside the hood at a distance close enough to the newborn to obtain feasible results not biased by the heater and fans airflow. To achieve this, use the custom 3D printed piece we provide at *SHTC3\_support.stl* and screw to the back wall. Moreover, for additional security, place an outdoor thermometer with alarm system completely independent of the control system approximately in the same position as the SHTC3 sensor, this time, by using the support piece already given by the product. Then place the sensor's temperature monitor in the upper right corner of the incubator's front face (Fig. 1) as a security feature in case the device's electronic components failed.

#### 5.5. Electronics

The schematic of the electronic circuit to be implemented is shown in Fig. 4.

The Printed Circuit Board was designed by using the PROTEL99SE software. The PCB layout of 5.83 cm × 8.09 cm can be envisioned in Fig. 5 as well as attached in JPG format in the PCB folder. By using these files, the circuit can be replicated manually either by photolithography or by sending them to specialized production centers.

Place the PCB in the 25 × 12 × 25 cm<sup>3</sup> drawer by using screws. Then, include the frontal wall of this structure, found in the attached *electronics\_drawer\_frontal\_part.stl*, containing all the information relevant to operate the incubator. More precisely, it presents the alarm, humidification, dehumidification and heater LEDs, the LCD screen, the adjust values pushbutton to change the LCD display, the two potentiometers to adjust the setpoints and an on/off switch to turn on and off the neonatal incubator. Additionally, it contains slits to dissipate heat and a knob for easy removal of the structure. After you complete the electronic drawer, perform the following connections:

- Place all the LEDs, potentiometers, switch and pushbutton connectors to the PLA front panel with short thin wires.
- Connect the heater, SHTC3 sensor and dehumidifying fan to their respective pins by lengthening the cables and performing two small holes in the incubator floor. Regarding the heater, use thicker cooper wires covered by a ground mesh to sustain high intensities.
- Connect the LED strip, used to improve visibility inside the dome in unfavorable conditions, and homogenization continuously to 12 V also by lengthening the cables and using the floor perforations.
- Connect the fan of the humidifying system and the humidifier from their respective drawer to the pins located in the neighboring electronic compartment.
- Allocate a 12 V power source next to the PCB and connect it to its respective pin. By means of performing a hole in the drawer and placing a plug at the rear of the incubator, the source could now be powered from the electrical network.

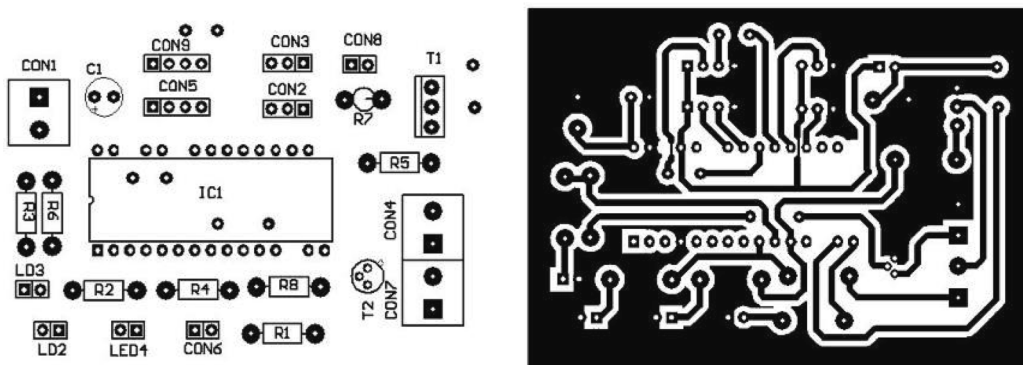

Fig. 5. PCB layout: components (left) and tracks (right).

To conclude with the prototype, gather the loose cables and place them inside gutters, thus improving aesthetics and reducing electrical shock hazard. The result should be similar to the one shown in Fig. 1.

5.6. Software

The Arduino code can be entirely found in the Code files. On-Off humidity control with hysteresis is implemented by comparing the current humidity value with humidity the desired setpoint, and, if lower, it activates the humidifying pump and adds 2 % to the setpoint value to activate augment the RH until arriving to the setpoint plus a two percent margin. If the RH value is higher than the setpoint plus the hysteresis, it eliminates the 2 % margin and turns off the humidifier until arriving to the setpoint, repeating this

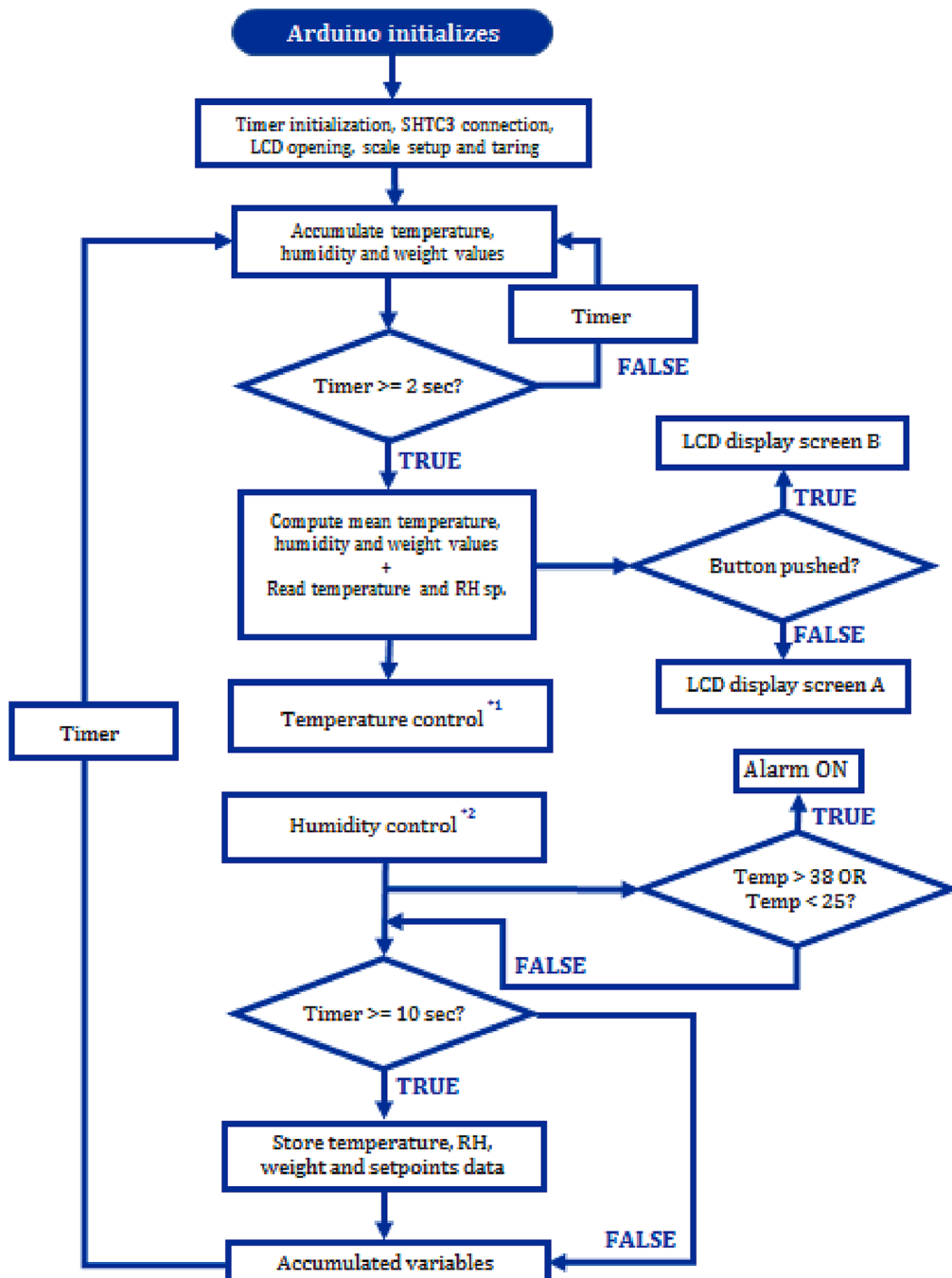

Fig. 6. General flowchart of the Arduino code.

procedure cyclically. When the RH value is higher than the setpoint value plus ten, i.e., we want to reduce the humidity notably; it activates the dehumidifying fan and adds two to the setpoint to account for the descending inertia. Then, when found at the setpoint plus a two percent margin, it repeats the cyclical behavior stated previously.

For the temperature, in order to apply a PID control the PID library from Arduino is used. With this function, the PID system could be initialized by using the *myPID* function, and later be used to have as input parameters the PID input (which is the current feedback value), the PID setpoint and Kp (50), Ki (5) and Kd (0) values (determined via the trial-and-error method) to return a PID output value by using the *Compute()* method. Moreover, a window size object was initialized to determine the limit of the output value with the *SetOutputLimits()* function. Finally, the PID output, which is the control action, was compared with the *millis()* timer, elapsed time, minus *t0\_PID* variable, which actualizes each time we surpass the output limit, to determine whether the transistor that controls the opening and closing of the heater should be on or off (threshold).

For the general behavior of the code (actuators, indicators, ...) a visual general flowchart was created and displayed on Fig. 6, with temperature and humidity control explained extended in Figs. 7 and 8.

### 6. Operation instructions

To operate the neonatal incubator, follow the subsequent instructions:

- To turn on the device, once connected to the electrical network, pull up the switch located on the left–right side of the electronics drawer (Fig. 9). This will automatically power the Arduino device, and it will turn on the LED strip and the homogenization fan.
- Once the neonatal incubator is powered, the temperature (in °C), the RH (in %) and the weight (in Kg) are displayed in the LCD screen without the need of pushing any button (Fig. 9). Note that the weight value displayed will only be acceptable when the newborn’s bed is completely flat.
- To visualize the temperature and RH setpoints, keep the Adj. Values pushbutton located at the top of the on–off switch pressed. To adjust the temperature and RH setpoints, keeping the Adj. Values pushbutton pressed, turn the temperature or humidity potentiometers selecting the desired consign that you want to reach inside the incubator’s hood.
- To tilt the newborn’s bed to the desired inclination, lift the bed right section by the PLA handle and place the custom wooden wedge underneath.
- When the water level inside the humidifier is low, the device will stop working until the water tank is refilled. To do that, take out the humidifier drawer, open it and lift the lid of the plastic container. Subsequently, introduce 1,2 L of water inside of it, close it again and fix the humidifier drawer to the barrier by means of the fit between the PVC pipe and its adapter.
- When any of the alarm systems (internal or external) activates, immediately extract the baby from the incubator.

### 7. Validation and characterization

In order to properly validate the neonatal incubator, it was tested by using the IEC 60601–2-19 standards [10].

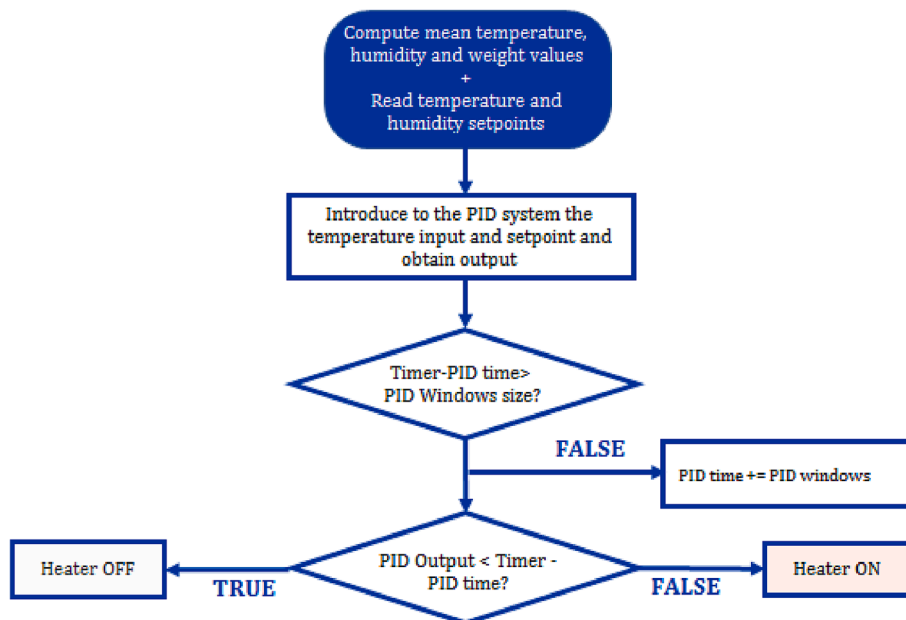

Fig. 7. Temperature control flowchart.

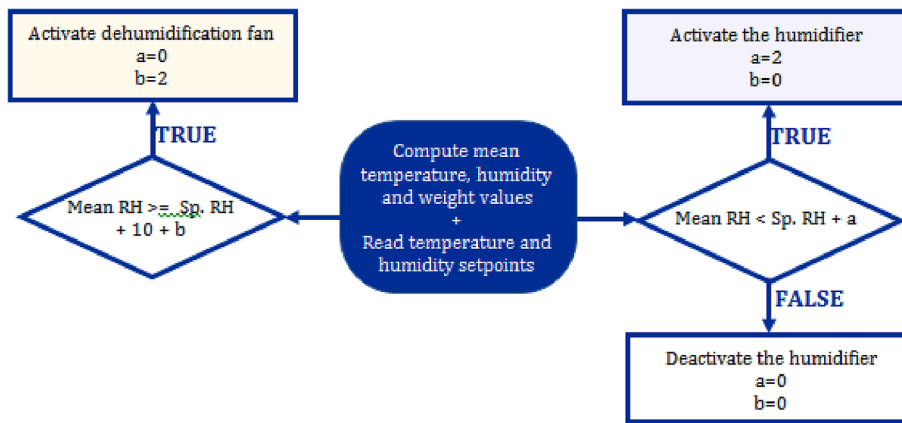

Fig. 8. Humidity control flowchart.



Fig. 9. Frontal wall of the electronics drawer without pressing the pushbutton.

7.1. Temperature and humidity steady test

The temperature and humidity inside the incubator, with the sensor found in the middle part of the rear wall, and outside the prototype, with an external SHTC3 sensor, were recorded for 24 h when set points of 36 °C and 60% were prescribed respectively. The results are shown in Fig. 10. Note that for this test to be acceptable, the ambient temperature outside the incubator must be in the range of 21 °C to 26 °C [10].

It can be observed that temperature was maintained steady in a range of 36 ± 0.1 °C during the whole test, arriving to this temperature after 45 min starting from a 25.4° ambient temperature with an overshoot of 0.35 °C. These results tell us that for the

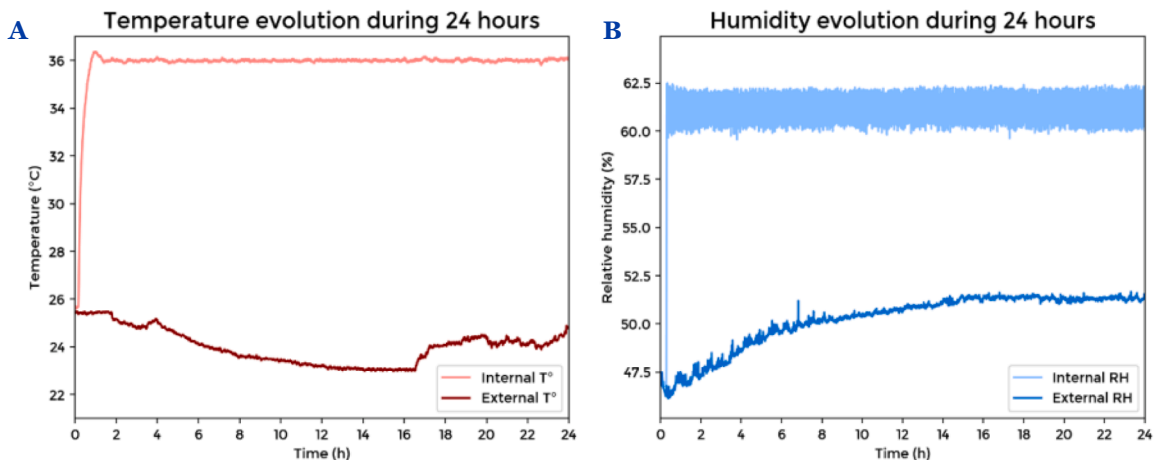

Fig. 10. Temperature (A) and humidity (B) evolution for the 24 h test.



temperature variable, the system has passed satisfactorily the specification that says that for the steady tests the temperature should not differ more than  $\pm 0.5$  °C of the setpoint value (fixed to 36 °C) [10]. Regarding the humidity, starting from an environmental RH of 47 %, the implemented incubator was capable of raising this value to 60 % in less than five minutes, obtaining a RH fluctuating between 60 % and 62.5 %, (within the  $\pm 10$  % of the humidity setpoint that regulations indicate).

### 7.2. Transient response

Transient response was tested by setting a temperature setpoint of 36 °C and a humidity setpoint 60 %; once the steady state was achieved, the door of the incubator was opened for 5 min, simulating an interaction of a medical professional with the newborn. Results are shown in Fig. 11.

The temperature inside the incubator was reduced to 31.9 °C during the five minutes period where the door was opened. Then, the steady state was recovered in approximately 13 min with an overshoot of 0.5 °C, demonstrating that the steady state response is fast enough and does not exceed the  $\pm 0.5$  °C deviation from the setpoint for more than one minute.

To further check if the system can adapt correctly to changing the temperature and humidity setpoints, a heating, humidification and dehumidification stair protocol was performed. Starting from an incubator air temperature of 26.2 °C and a humidity of 58.7 %, the temperature setpoint was fixed to 35 °C while the RH setpoint was set at 70 %. After 95 min, the humidity setpoint was reduced to 60 %, arriving to this new value in less than 2 min owing to the dehumidifying fan. This action of the fan also caused the temperature to drop 0.5 °C (as it introduced cold outside air), but it was countered by the PID system in 5 min with an overshoot fewer than 0.6 °C, demonstrating that the incubator could correct small variations in temperature even in ranges less than 0.5 °C. Subsequently, 160 min after the start of the test, the temperature setpoint was risen one degree, arriving to that new consign in 15 min and with an overshoot of 0.4 °C. To conclude with the test, 50 min after the temperature setpoint change, the humidity setpoint was increased to 75 %, achieving that setpoint in a slower time than before (9 min), and making the temperature decrease 1.2 °C due to the entrance of cold external air because of the humidifying fan and cold water particles coming from the humidifier container. This bigger diminish was also corrected by the system in 15 min and an overshoot of 0.2 °C, which was fast as the whole hood was already tempered. Fig. 13 shows the results of the aforementioned test.

### 7.3. Heat distribution test

This test was performed to check for homogeneity in the heat distribution of the hood with a Hti-Xintai 19 thermal camera. We wanted to make sure that, by using the homogenization fan, the whole body of the infant will be exposed to the same temperature (or within the  $\pm 0.5$  °C range). To ensure these criteria, 36 °C and 60 % of RH were fixed inside the incubator during one hour with just the newborn blanket and a picture with the thermal camera was performed (Fig. 13 E). Subsequently, the same procedure was performed but introducing a PLA printed phantom of 1.4 kg and 50 cm height (Fig. 13A,B,C) to envision the heat distribution more clearly in a material shaped as a newborn. Additionally, an image of the whole incubator in normal working conditions was also obtained with the thermal camera to evaluate leakages (Fig. 13D).

As can be observed in Fig. 13, the heat distribution in the phantom and the blanket are highly homogeneous, with discrepancies of approximately 0.2 °C between the infant head and feet. The only parts of the infant dummy that present lower temperatures were the ones located at the back parts (nape and back of leg), but these sections also not differ more than 0.5 °C with respect to the highest temperature. Therefore, the infant will evolve correctly. We must note that the dummy is energetically passive and the temperatures it presents on the skin do not represent the temperature a real newborn would have (due to the heat dissipation generated by its metabolism [13]). The external image of the incubator (Fig. 14E) did not reveal obvious leaks.

### 7.4. Noise isolation test

To evaluate that the internal incubator mechanism was not excessively noisy, which could be harmful to the infant [11,12], the noise level was measured inside the device for quiet external conditions before and after turning on the neonatal incubator. To perform this test the Hibok 401 sonometer was used, obtaining results of 38.4 dB and 47.2 dB with the device turned off and on respectively. We can determine from these sound levels that the internal ultra-silent fans and heater emit noise in the 10 dB range when operating, indicating that they do not reach the dangerous 60 dB levels specified in [10]. As a result, no extra insulating systems are required unless the incubator is placed in a noisy setting, such as a crowded hospital ward or a street.

### 7.5. Weight test

A 6 L carafe was sequentially filled and weighted with a high-quality scale in steps of 250 g until arriving to 5.5 kg. The weight evolution was measured every 10 s in the neonatal incubator system keeping the bed flat (Fig. 12A) and the values obtained were compared with the superior scale, which in the graphs we call them real weights (Fig. 12B).

From Fig. 14 we can conclude that the weighting system coupled to the incubator's bed was completely capable of measuring weight changes in the premature newborn for the normal range of weights they present (between 1 and 3 kg).

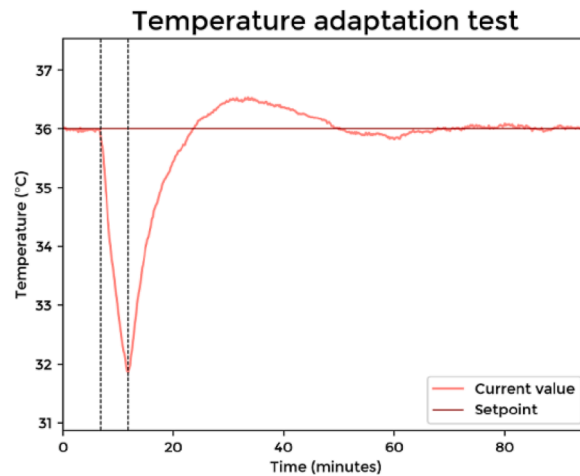

Fig. 11. Temperature adaptation test.

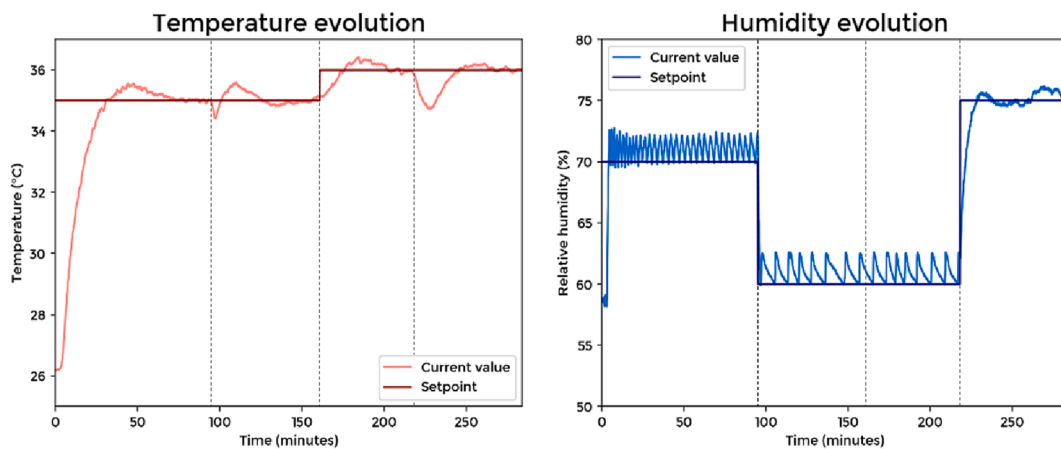

Fig. 12. Transient response for the heating, humidification and dehumidification test. Dashed lines represent a change in one of the two setpoints.

## 8. Discussion and conclusions

There are some low-cost approaches for incubators that perform similar functions as the current device, such as the ones described by Tran et al. [14], Zaylaa et al. [15] or Fong et al. [16], but the neonatal incubator presented herein has a reduced cost as well as additional features (such as weight monitoring or an external alarm system), and an updated design with current materials found at e-commerce platforms such as Amazon or AliExpress. In this way, the incubator can be replicated and utilized by potential users in LMICs just by following the detailed instructions we provide in this work. The incubator presented herein will add to many other devices [17–20], which based on Arduino control, may contribute to improve the healthcare of patients who otherwise could not be adequately treated.

The design presented herein is thought to be the basis for the implementation of incubators with improved characteristics. This basic implementation can be potentially improved by paying more attention to aspects such as sanitation and robustness. For instance, the wood used to implement the incubator walls can be varnished or covered with adhesive plastic sheets, and the fans can be placed externally with an added filter to simplify cleaning. Finally, depending on the facilities available in the center of production (sensors, cameras, etc), customized protocols to test the devices finally fabricated could be implemented.

Overall, the accessible and easy-to-assemble device we present here can benefit the healthcare centers in under-resourced regions by:

- Providing a permanent newborn infant incubator for a LMIC medical center that does not have one and is geographically distant from a larger hospital.
- Providing an additional neonatal incubator to be used in case of overloading.
- Providing a neonatal incubator for short-term situations such as temporary refugee camps.

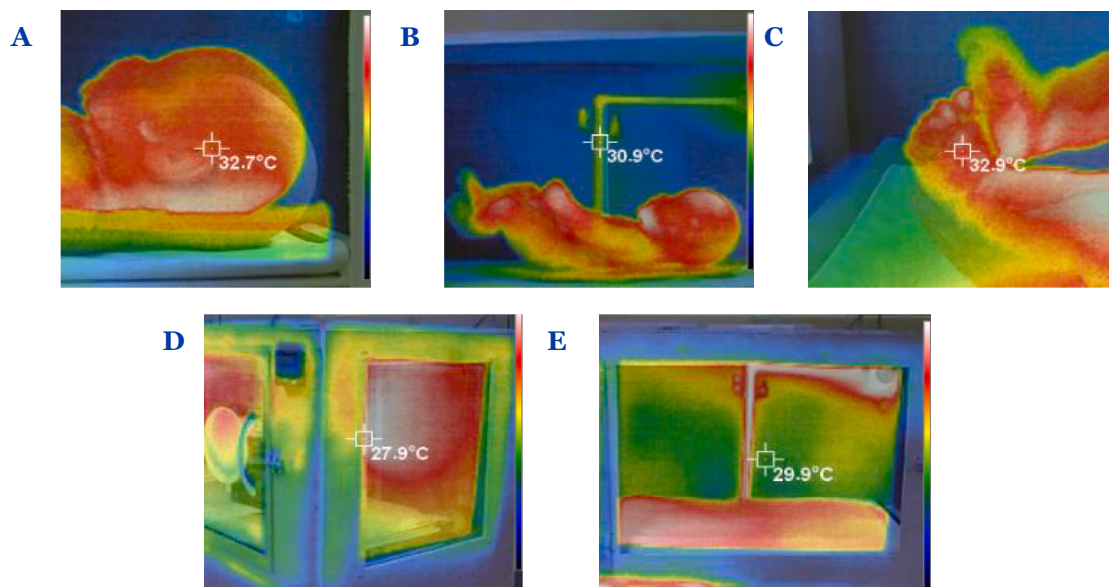

**Fig. 13.** Thermal camera image of the newborn (B), its head (A) and its feet (C), the newborn blanket (E) and the incubator (D) for internal conditions of 36 °C and 60 % conditions.

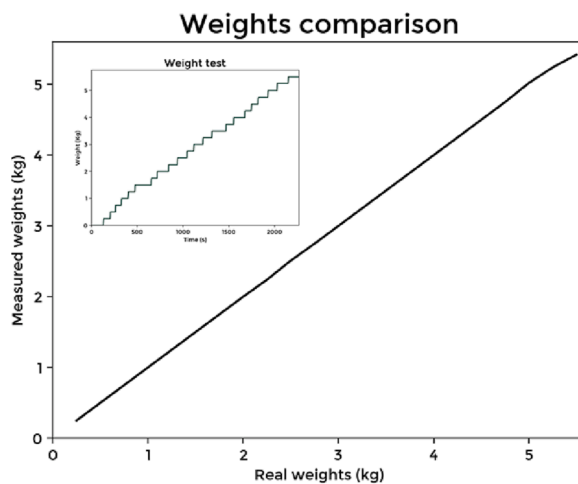

**Fig. 14.** Comparison of the results of the weigh measurement incorporated in the incubator with respect to a high-resolution scale and experiment of weight test (inset).

#### Declaration of Competing Interest

The authors declare that they have no known competing financial interests or personal relationships that could have appeared to influence the work reported in this paper.

#### Acknowledgments

This research did not receive any specific grant from funding agencies in the public, commercial, or not-for-profit sectors.

#### Appendix A. Supplementary data

Supplementary data to this article can be found online at <https://doi.org/10.1016/j.ohx.2023.e00457>.

## References

- [1] L. Liu, S. Oza, D. Hogan, Y. Chu, J. Perin, J. Zhu, J.E. Lawn, S. Cousens, C. Mathers, R.E. Black, Global, regional, and national causes of under-5 mortality in 2000–15: an updated systematic analysis with implications for the Sustainable Development Goals, *Lancet* 388 (10063) (2016 Dec 17) 3027–3035.
- [2] L. Hug, M. Alexander, D. You, L. Alkema, National, regional, and global levels and trends in neonatal mortality between 1990 and 2017, with scenario-based projections to 2030: a systematic analysis, *Lancet Glob. Health* 7 (6) (2019) e710.
- [3] A. Chandrasekaran, P. Amboiram, U. Balakrishnan, T. Abiramalatha, G. Rao, S.M.S. Jan, U.D. Rajendran, U. Sekar, G. Thiruvengadam, B. Ninan, Disposable low-cost cardboard incubator for thermoregulation of stable preterm infant - a randomized controlled non-inferiority trial, *EClinicalMedicine* 7 (31) (2020 Dec), 100664.
- [4] D. Trevisanuto, D. Testoni, M.F.B. de Almeida, Maintaining normothermia: Why and how? *Semin. Fetal Neonatal. Med.* 23 (5) (2018 Oct) 333–339.
- [5] J.P. Baker, The incubator and the medical discovery of the premature infant, *J. Perinatol.* 20 (5) (2000) 321–328.
- [6] K. Lunze, D.H. Hamer, Thermal protection of the newborn in resource-limited environments, *J. Perinatol.* 32 (5) (2012 May) 317–324.
- [7] E.O. Boundy, R. Dastjerdi, D. Spiegelman, W.W. Fawzi, S.A. Missmer, E. Lieberman, S. Kajeepeeta, S. Wall, G.J. Chan, Kangaroo Mother Care and Neonatal Outcomes: A Meta-analysis, *Pediatrics* 137 (1) (2016 Jan).
- [8] R.R. Kostandy, S.M. Ludington-Hoe, The evolution of the science of kangaroo (mother) care (skin-to-skin contact), *Birth Defects Res.* 111 (15) (2019 Sep 1) 1032–1043.
- [9] S.-H. Niermeyer, *Merenstein & Gardner's Handbook of Neonatal Intensive Care*, Elsevier, 2020 Feb 5.
- [10] International Electrotechnical Commission. IEC 60601-2-19:2009. Medical electrical equipment - Part 2-19: Particular requirements for the basic safety and essential performance of infant incubators. IEC. 2009.
- [11] J.G. Long, J.F. Lucey, A.G. Philip, Noise and hypoxemia in the intensive care nursery, *Pediatrics* 65 (1) (1980 Jan) 143–145.
- [12] E.M. Pinheiro, R. Guinsburg, M.A.d.A. Nabuco, T.Y. Kakehashi, Noise at the neonatal intensive care unit and inside the incubator, *Rev. Lat. Am. Enfermagem.* 19 (5) (2011) 1214–1221.
- [13] K. Gregory, Update on nutrition for preterm and full-term infants, *J. Obstet. Gynecol. Neonatal. Nurs.* 34 (1) (2005) 98–108.
- [14] K. Tran, A. Gibson, D. Wong, D. Tilahun, N. Selock, T. Good, G. Ram, L. Tolosa, M. Tolosa, Y. Kostov, H.C. Woo, M. Frizzell, V. Fulda, R. Gopinath, J.S. Prasad, H. Sudarshan, A. Venkatesan, V.S. Kumar, N. Shylaja, G. Rao, Designing a Low-Cost Multifunctional Infant Incubator, *J. Lab. Autom.* 19 (3) (2014 Jun) 332–337.
- [15] A.J. Zaylaa, M. Rashid, M. Shaib, I. El Majzoub, A Handy Preterm Infant Incubator for Providing Intensive Care: Simulation, 3D Printed Prototype, and Evaluation, *J. Healthc. Eng.* 10 (2018) (2018 May) 8937985.
- [16] Fong, Richard; Gallardo, Guillermo; Jeffery, William; Maeda, Danny; and Romero, Gabriel. Project Omooverhi : low-cost, neonatal incubator. Interdisciplinary Design Senior Theses. 2013; 3.
- [17] R. Farré, J.M. Montserrat, G. Solana, D. Gozal, D. Navajas, Easy-to-build and affordable continuous positive airway pressure CPAP device for adult patients in low-income countries, *Eur. Respir. J.* 53 (5) (2019) 1802290, <https://doi.org/10.1183/13993003.02290-2018>.
- [18] C. Aymerich, M. Rodríguez-Lázaro, G. Solana, R. Farré, J. Otero, Low-Cost Open-Source Device to Measure Maximal Inspiratory and Expiratory Pressures, 719372, *Front. Physiol.* 12 (2021), <https://doi.org/10.3389/fphys.2021.719372>.
- [19] O. Garmendia, M.A. Rodríguez-Lázaro, J. Otero, P. Phan, A. Stoyanova, A.T. Dinh-Xuan, D. Gozal, D. Navajas, J.M. Montserrat, R. Farré, Low-cost, easy-to-build noninvasive pressure support ventilator for under-resourced regions: open source hardware description, performance and feasibility testing, *Eur. Respir. J.* 55 (6) (2020) 2000846, <https://doi.org/10.1183/13993003.00846-2020>.
- [20] R. Farré, M.A. Rodríguez-Lázaro, A.T. Dinh-Xuan, M. Pons-Odena, D. Navajas, D. Gozal, A Low-Cost, Easy-to-Assemble Device to Prevent Infant Hyperthermia under Conditions of High Thermal Stress, *Int. J. Environ. Res. Public Health* 18 (24) (2021) 13382, <https://doi.org/10.3390/ijerph182413382>.



Currently Assistant Professor at the Unit of Biophysics and Biomedicine of the Medical School at the University of Barcelona, Dr. Otero is Computer Scientist, Electronic and Biomedical Engineer and holds a Ph.D. in Biomedicine. He has published in top journals ranging from engineering and physics to biology. During his predoctoral and postdoctoral formation, Dr. Otero has been active in different national and European research projects- Dr. Otero is currently working on biomedical engineering at the School of Medicine, where he is the principal investigator of the project HYBRID (High-Yield fabrication of Biomechatronic hydrogel devices for Respiratory Injury and Disease Modelling).